

WTMC4A2 - ENSEMBLE KIT ASSEMBLY DIAGRAM

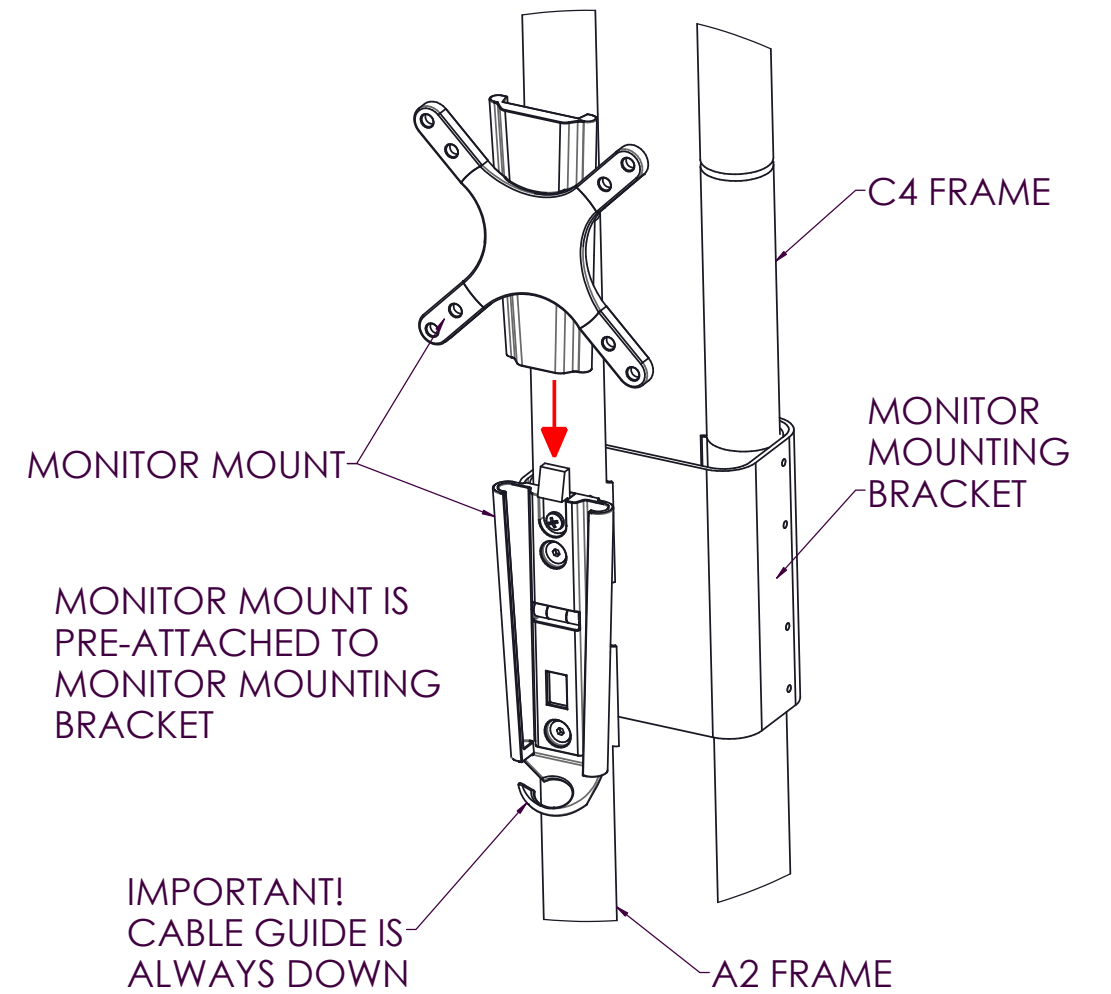
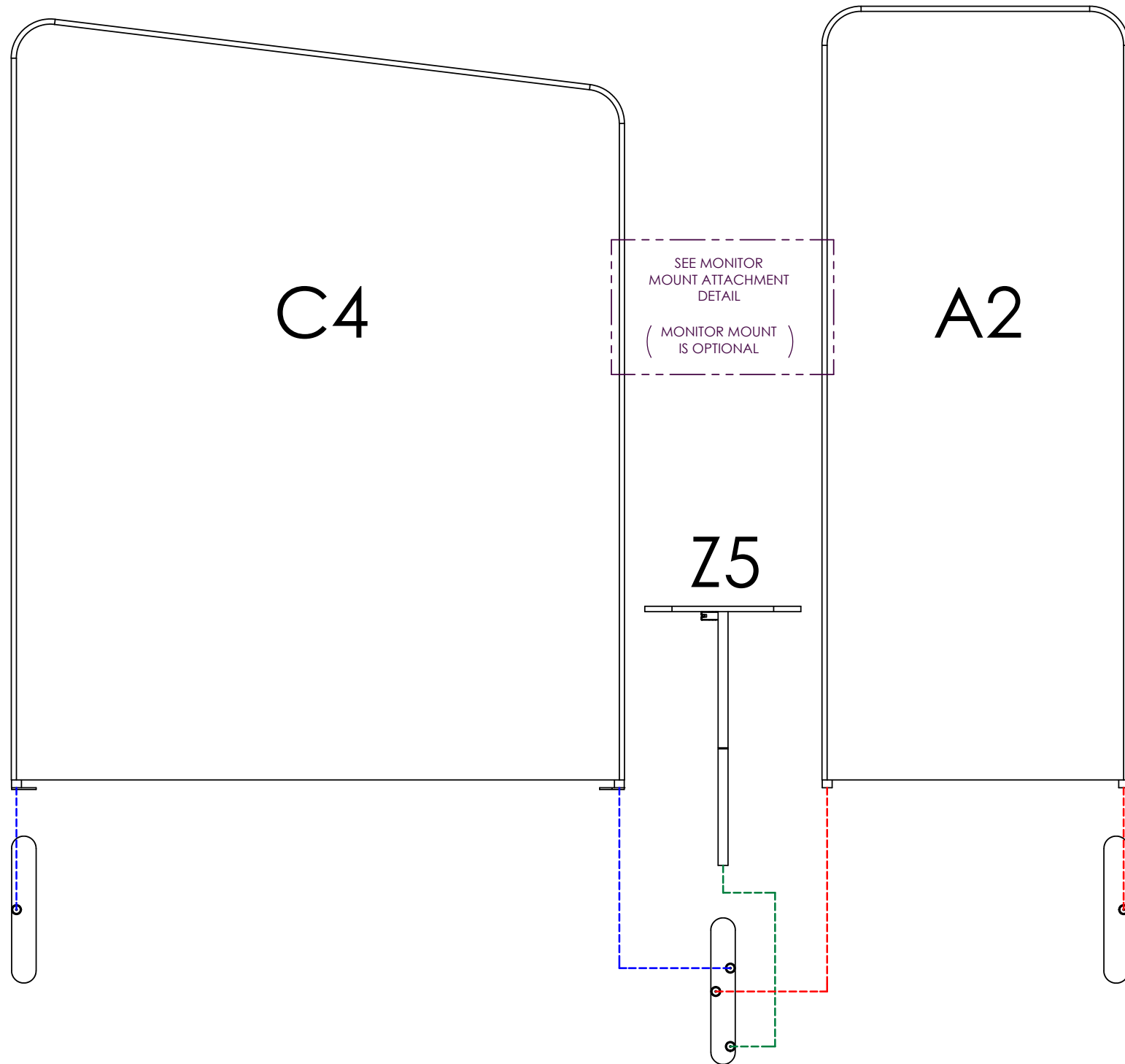

MONITOR MOUNT ATTACHMENT DETAIL
(MONITOR MOUNT IS OPTIONAL)

FINISH:	THIRD ANGLE PROJECTION	PROPRIETARY
MATERIAL:		THIS DOCUMENT AND DATA DISCLOSED HEREIN OR HEREWITH IS NOT TO BE REPRODUCED, USED, OR DISCLOSED IN WHOLE OR IN PART TO ANYONE WITHOUT PERMISSION OF NIEDO GROUP, INC.
DIMENSIONS ARE IN MILLIMETERS	NIEDO GROUP, INC. 5465 SW WESTERN AVE. BEAVERTON, OR 97005	
TOLERANCES UNLESS OTHERWISE SPECIFIED	TITLE	
	WAVE TUBE MODULAR C4A2 ENSEMBLE, ASSEMBLY	
SCALE: 1:50	DO NOT SCALE DRAWING	SHEET 1 OF 1
REV 01		

HOW TO DETERMINE IF YOU NEED A LEFT OR RIGHT SIDE MONITOR MOUNT OR TABLE

LEFT HAND MONITOR MOUNTS ARE LOCATED ON THE LEFT SIDE OF THE OVERLAPPING PANEL

RIGHT HAND MONITOR MOUNTS ARE LOCATED ON THE RIGHT SIDE OF THE OVERLAPPING PANEL

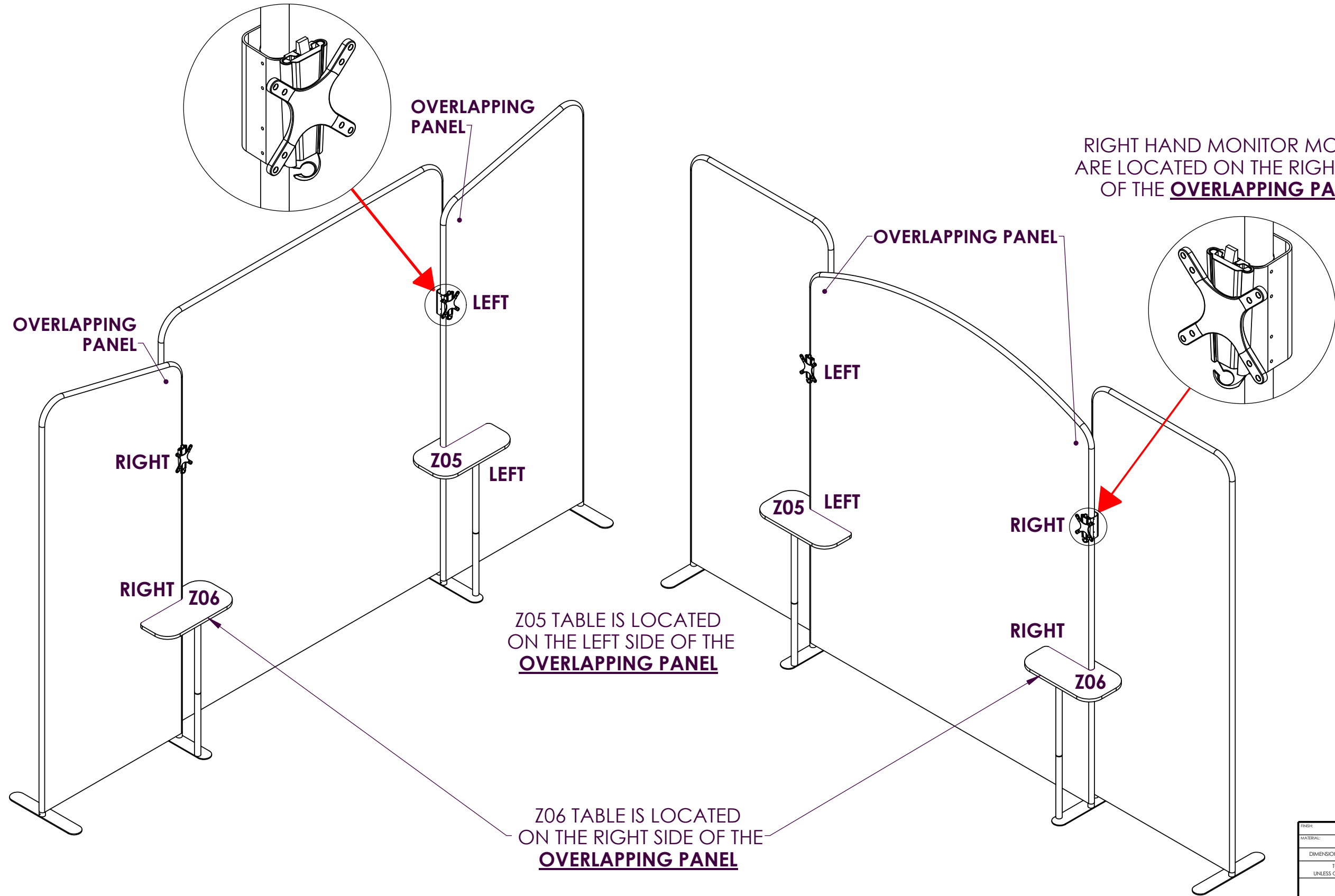

Z05 TABLE IS LOCATED ON THE LEFT SIDE OF THE OVERLAPPING PANEL

Z06 TABLE IS LOCATED ON THE RIGHT SIDE OF THE OVERLAPPING PANEL

FINISH:	THIRD ANGLE PROJECTION	PROPRIETARY
MATERIAL:		THIS DOCUMENT AND DATA DISCLOSED HEREIN OR HEREWITH IS NOT TO BE REPRODUCED, USED, OR DISCLOSED IN WHOLE OR IN PART TO ANYONE WITHOUT PERMISSION OF NIEDO GROUP, INC.
DIMENSIONS ARE IN MILLIMETERS	NIEDO GROUP, INC. 5465 SW WESTERN AVE. BEAVERTON, OR 97005	
TOLERANCES UNLESS OTHERWISE SPECIFIED	TITLE: WAVE TUBE MODULAR MONITOR MOUNT & TABLE DETAIL ENSEMBLY, ASSEMBLY	
SIZE: B	DWG. NO.: Generic Top View	REV: 03
SCALE: 1:50	DO NOT SCALE DRAWING	SHEET 1 OF 1

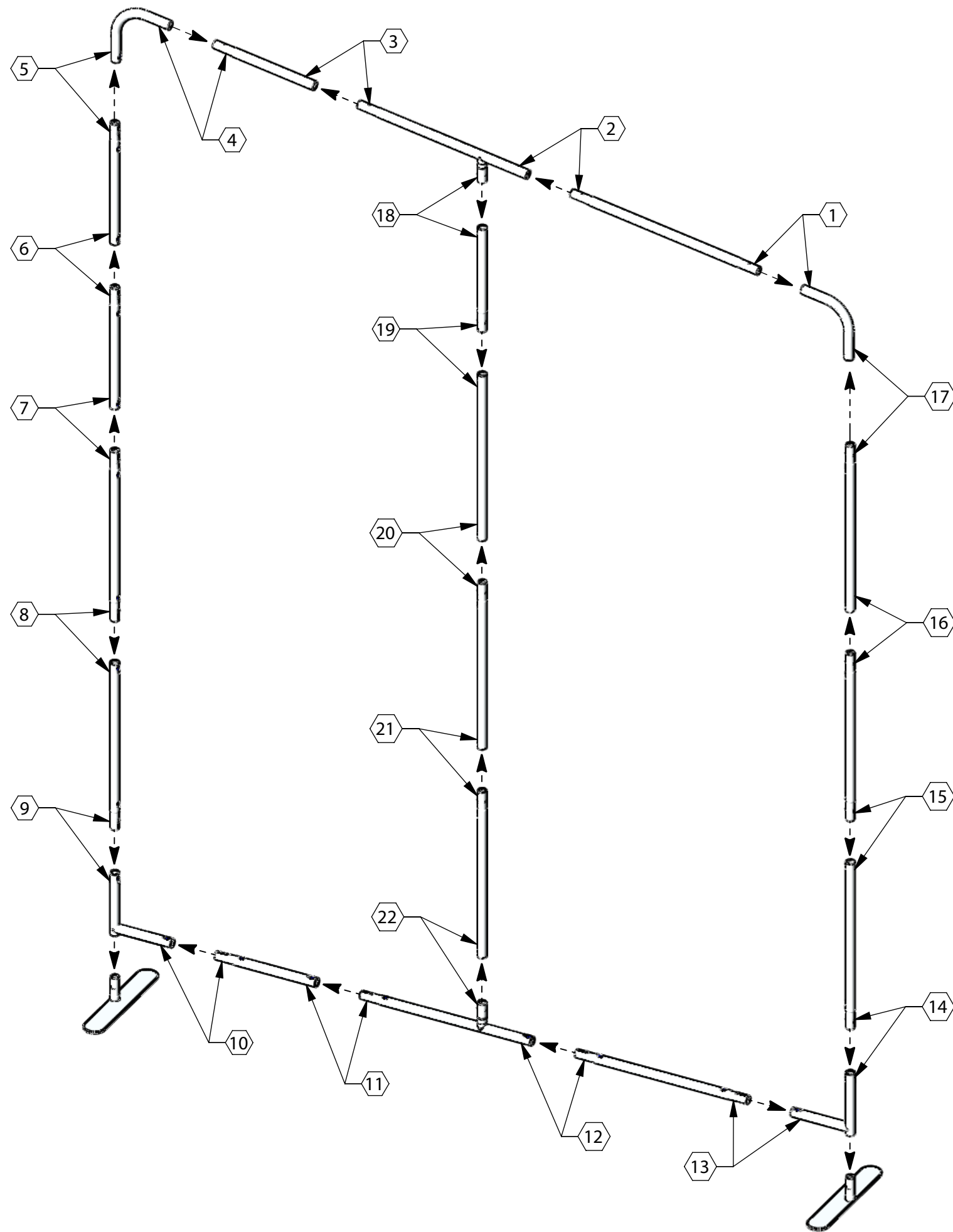

REVISIONS			
REV	DESCRIPTION	ENGINEER	DATE
AA	INITIAL RELEASE	D. OWENS	02/08/18

NOTES: UNLESS OTHERWISE SPECIFIED:

1. ASSEMBLY TIME: 1 HOUR WITH 1 PERSON.
2. NUMBERED HEXAGONS MATCH THE NUMBERED LABELS ON EACH PART DURING ASSEMBLY.
3. FEET STYLE MAY VARY.

FINISH:		THIRD ANGLE PROJECTION		- PROPRIETARY - THIS DOCUMENT AND DATA DISCLOSED HEREIN OR HEREWITH IS NOT TO BE REPRODUCED, USED, OR DISCLOSED IN WHOLE OR IN PART TO ANYONE WITHOUT PERMISSION OF NIEDO GROUP, INC.	
MATERIAL: SEE B.O.M.		 NIEDO GROUP, INC.		5465 SW WESTERN AVE. BEAVERTON, OR 97005	
DIMENSIONS ARE IN MILLIMETERS		TITLE WAVE TABLE - BILL OF MATERIALS AND ASSEMBLY INSTRUCTIONS			
TOLERANCES UNLESS OTHERWISE SPECIFIED		SIZE B		DWG. NO. WTM-C4	
		SCALE: 1:14		SHEET 1 OF 2	
		DO NOT SCALE DRAWING		REV AA	

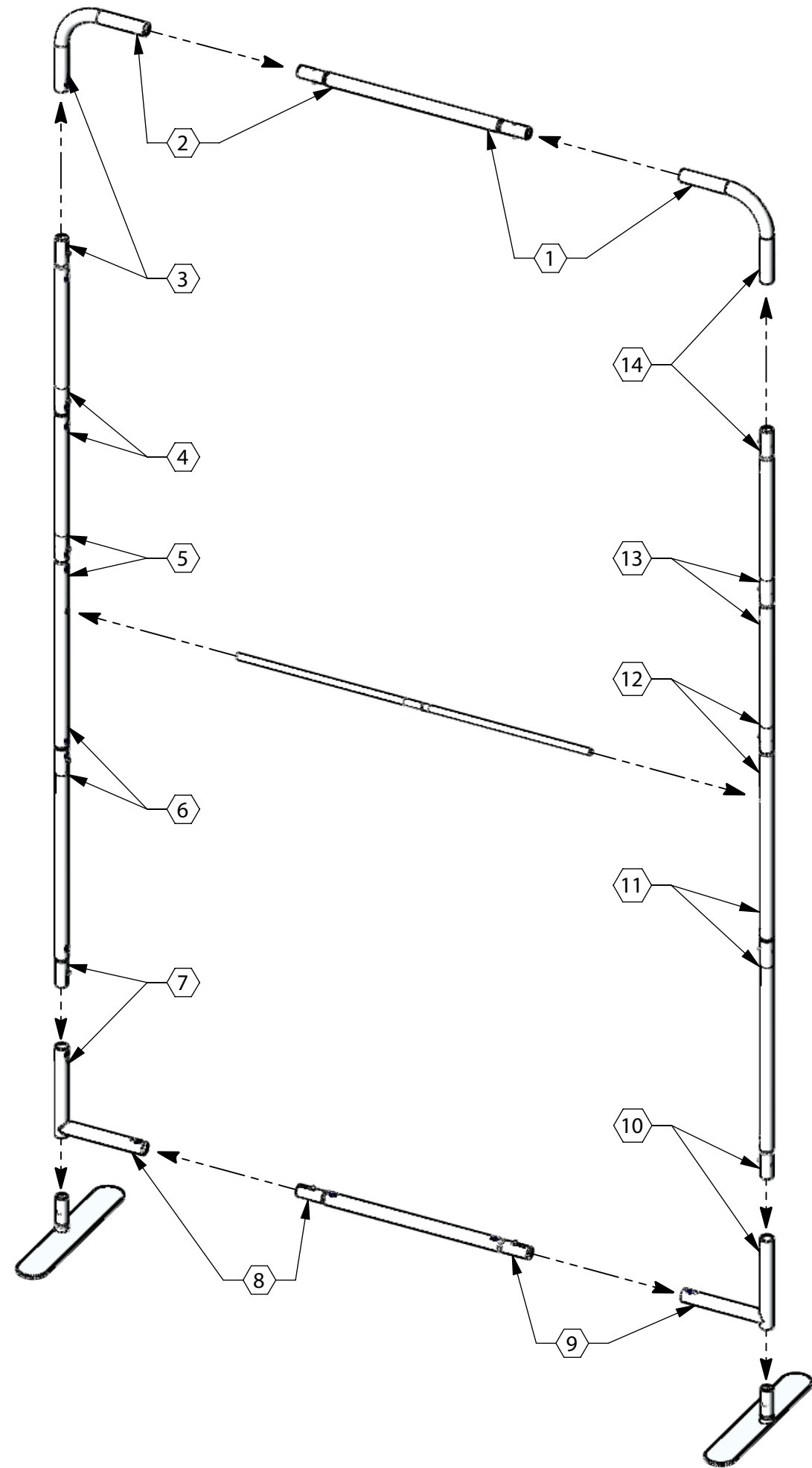

REVISIONS			
REV	DESCRIPTION	ENGINEER	DATE
AA	INITIAL RELEASE	D. OWENS	12/12/17

NOTES: UNLESS OTHERWISE SPECIFIED:

1. ASSEMBLY TIME: 1 HOUR WITH 1 PERSON.
2. NUMBERED HEXAGONS MATCH THE NUMBERED LABELS ON EACH PART DURING ASSEMBLY.
3. FEET STYLE MAY VARY.

FINISH:		THIRD ANGLE PROJECTION		- PROPRIETARY - THIS DOCUMENT AND DATA DISCLOSED HEREIN OR HEREWITH IS NOT TO BE REPRODUCED, USED, OR DISCLOSED IN WHOLE OR IN PART TO ANYONE WITHOUT PERMISSION OF NIEDO GROUP, INC.	
MATERIAL: SEE B.O.M.				NIEDO GROUP, INC. 5465 SW WESTERN AVE. BEAVERTON, OR 97005	
DIMENSIONS ARE IN MILLIMETERS		TITLE: WAVE TABLE - BILL OF MATERIALS AND ASSEMBLY INSTRUCTIONS			
TOLERANCES UNLESS OTHERWISE SPECIFIED		SIZE: B		REV: AA	
		DWG. NO.: WTM-A2		SHEET 1 OF 2	
SCALE: 1:20		DO NOT SCALE DRAWING			

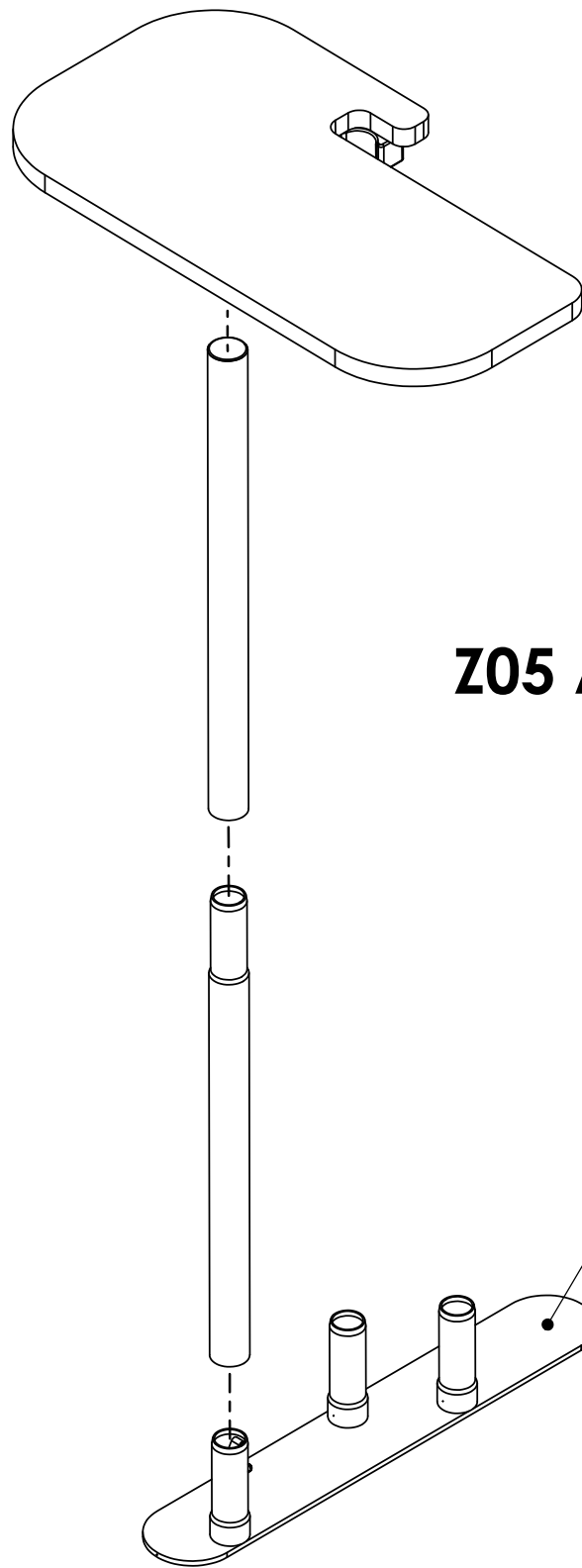

Z05 ASSEMBLY

FOOT ASSEMBLY

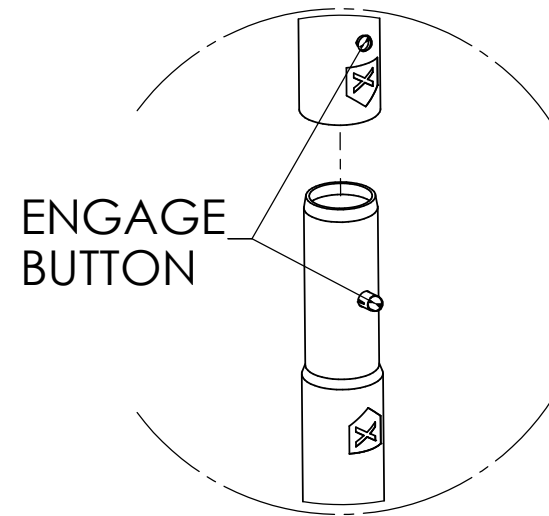

ENGAGE
BUTTON

GENERAL TUBE ASSEMBLY

FINISH:	THIRD ANGLE PROJECTION	PROPERTY
MATERIAL:		THIS DOCUMENT AND DATA DISCLOSED HEREIN OR HEREWITH IS NOT TO BE REPRODUCED, USED, OR DISCLOSED IN WHOLE OR IN PART TO ANYONE WITHOUT PERMISSION OF NIEDO GROUP, INC.
DIMENSIONS ARE IN MILLIMETERS		NIEDO GROUP, INC. 5465 SW WESTERN AVE. BEAVERTON, OR 97005
TOLERANCES UNLESS OTHERWISE SPECIFIED	TITLE	
	WAVE TUBE MODULAR WTM Z05 ASSEMBLY INSTRUCTIONS	
SIZE B	DWG. NO.	REV.
SCALE: 1:8	DO NOT SCALE DRAWING	SHEET 1 OF 1